



START HERE!

READ ME FIRST

Don't be a hero and muscle through this without first reading these fitting instructions! Improper installation of this gear may void certain aspects of your warranty.

Before you begin, take a moment and open all your Front Runner rack kit boxes and gather the assembly instructions for the various components.

A complete kit will contain:

1. A Front Runner Mounting System specific to your vehicle
2. A Front Runner Rack Tray or Load Bar Slats

This document will guide you through the assembly of the mounting system and assist you in fitting the roof rack tray or load bars to your specific vehicle.

Please refer to the next page for a list of all the components, quantities and tools required.

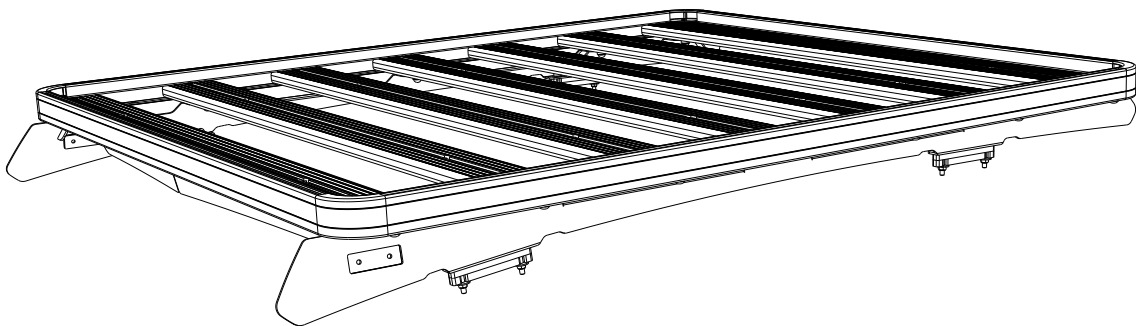

Front Runner will not be responsible for any damage caused by the failure to install the product according to these instructions. Please call us if you have any questions about the installation of this product.

IMPORTANT WARNING!

FRONT RUNNER CAN NOT RECOMMEND A MAXIMUM LOAD CARRYING CAPACITY. PLEASE REFER TO YOUR VEHICLE MANUFACTURER'S RECOMMENDATIONS. IT IS CRITICAL THAT ALL FRONT RUNNER PRODUCTS BE PROPERLY AND SECURELY ASSEMBLED AND ATTACHED TO YOUR VEHICLE. IMPROPER ATTACHMENT COULD RESULT IN AN AUTOMOBILE ACCIDENT, AND COULD CAUSE SERIOUS BODILY INJURY OR DEATH. YOU ARE RESPONSIBLE FOR ASSEMBLING AND SECURING ALL FRONT RUNNER PRODUCTS TO YOUR VEHICLE. CHECKING THE ATTACHMENTS PRIOR TO USE, AND PERIODICALLY INSPECTING THE PRODUCTS FOR ADJUSTMENT, WEAR AND DAMAGE. THEREFORE YOU MUST READ AND UNDERSTAND ALL OF THE INSTRUCTIONS AND PRECAUTIONS SUPPLIED WITH YOUR FRONT RUNNER PRODUCT PRIOR TO INSTALLATION OR USE. IF YOU DO NOT UNDERSTAND ALL OF THE INSTRUCTIONS AND CAUTIONS, OR IF YOU HAVE NO MECHANICAL EXPERIENCE AND ARE NOT THOROUGHLY FAMILIAR WITH THE INSTALLATION PROCEDURES, YOU SHOULD HAVE THE PRODUCT INSTALLED BY A PROFESSIONAL INSTALLER OR OTHER QUALIFIED PERSONNEL.



1 GET ORGANIZED

IN THE BOX

1	2 X	Foot Rail: 1xLH, 1xRH
2	8 X	M6 Nut Cap
3	8 X	M6x50 Hex Bolt
4	8 X	M6 Spring Washer
5	8 X	M6x19 Flat Washer
6	10 X	M8x20 Hex Bolt
7	4 X	M6 Nut Plate
8	10 X	M8x16 Flat Washer
9	10 X	M8 Nyloc Nut
10	10 X	M8 Nut Cap
11	1 X	Template
12	12 X	Foot Rail Sealing Kit (RRAC082)

TOOLS NEEDED

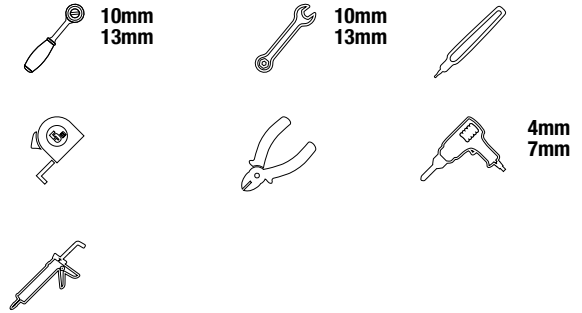
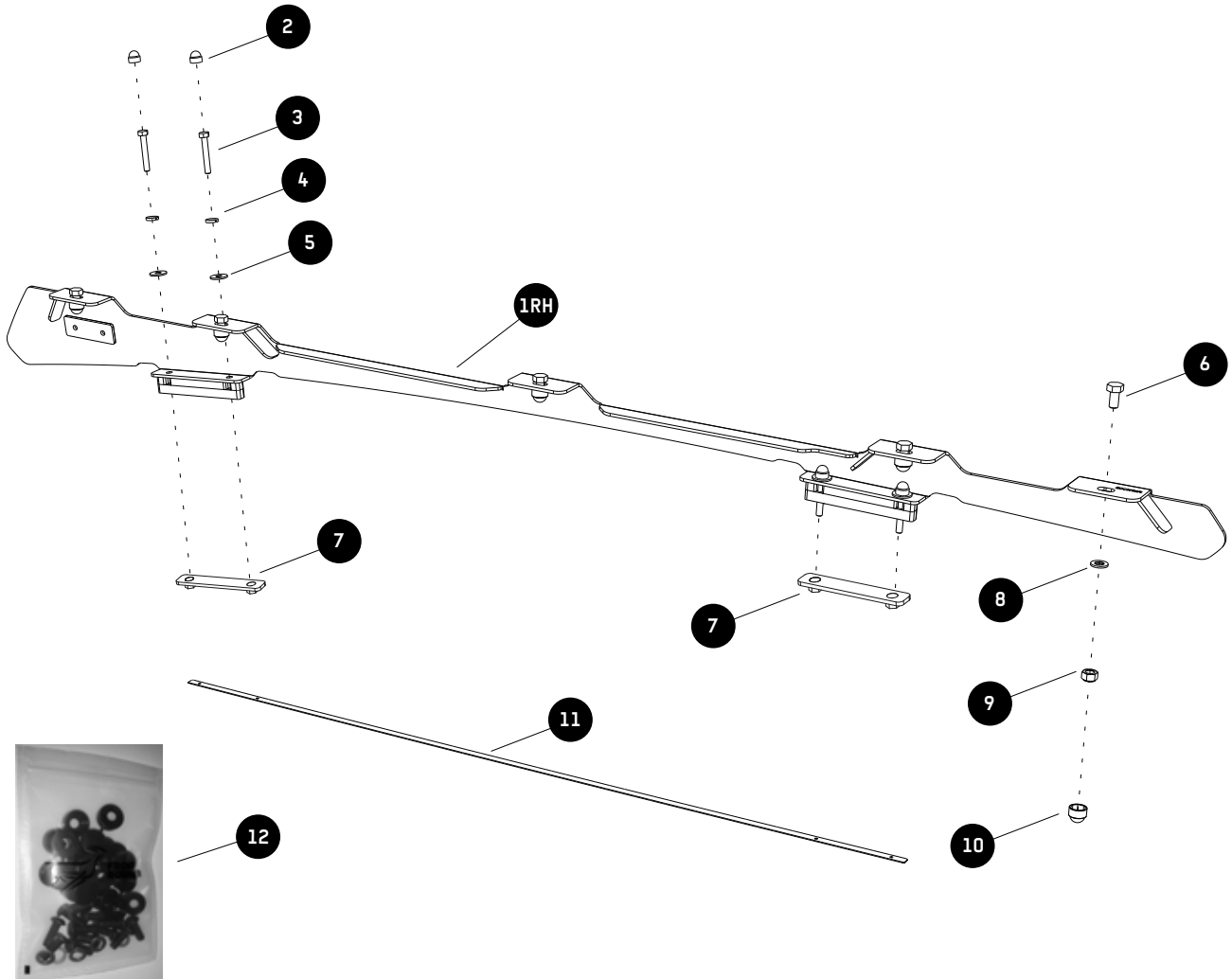
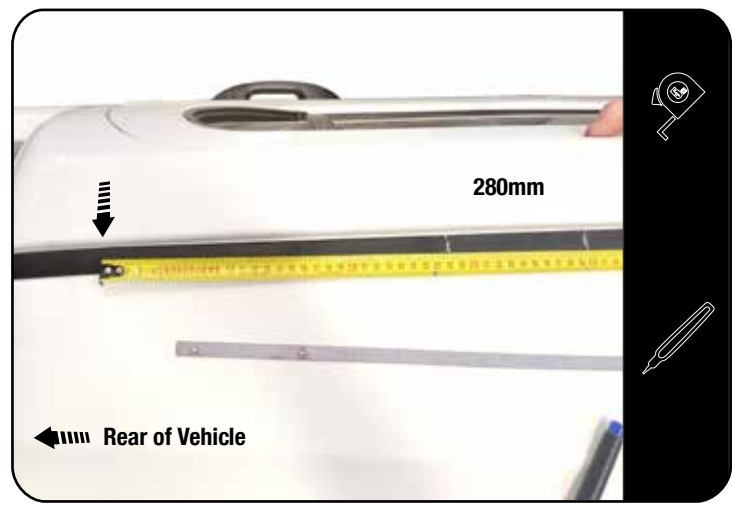

FIGURE 1.1



2 FIT AND SECURE

2.1



From the Tool Mark on the Ditch Moulding, measure 280mm toward the Front of the Vehicle. Make a Line with a marker.

2.2

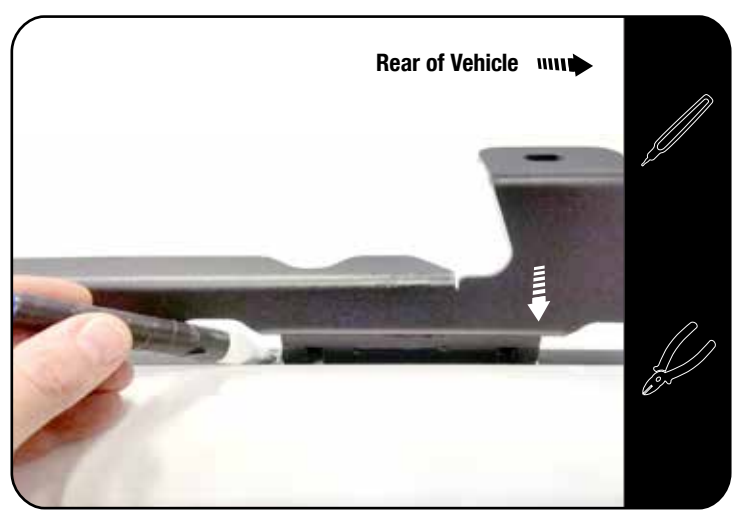

Place the Foot Rail on the Ditch Moulding, with the heel of the Foot Rail against the line made in Step 2.1
 Mark the remaining foot positions.
 Lift the moulding and trim out each section where the Feet will sit. (2 per Foot Rail)

2.3

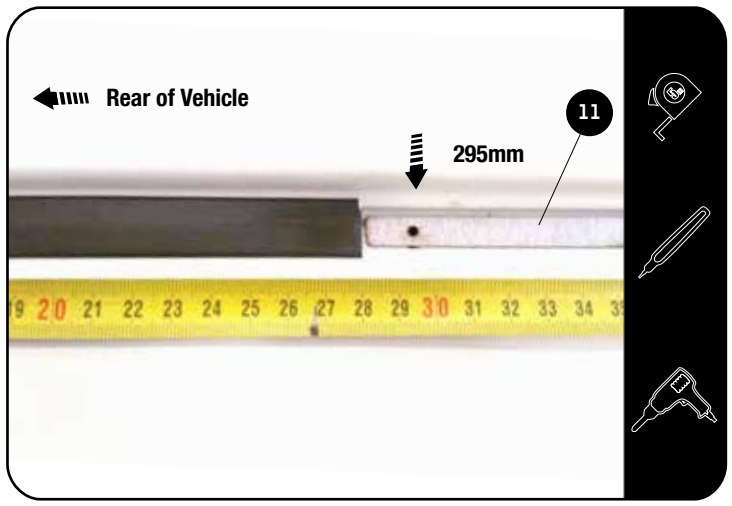

Measure 295mm from the Tool Mark on the Ditch Moulding and make a mark in the Ditch.
 Place the Template (Item 11) in the Ditch, aligning the first hole with the mark you just made. Mark all 4 Holes Clearly.
 Remove the Template and drill a 4mm Pilot hole on the 8 markings made (4 per side). Re Drill the holes using a 7mm Drill.

2.4

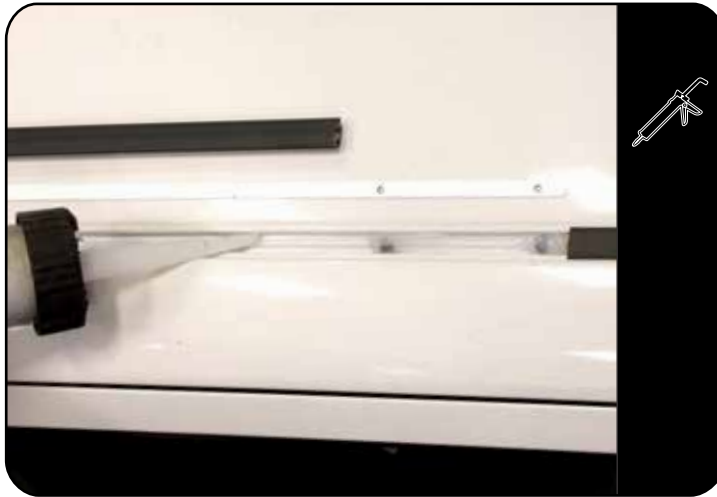

Apply Anti Rust and Sealent to the Holes and Ditch.

2.5

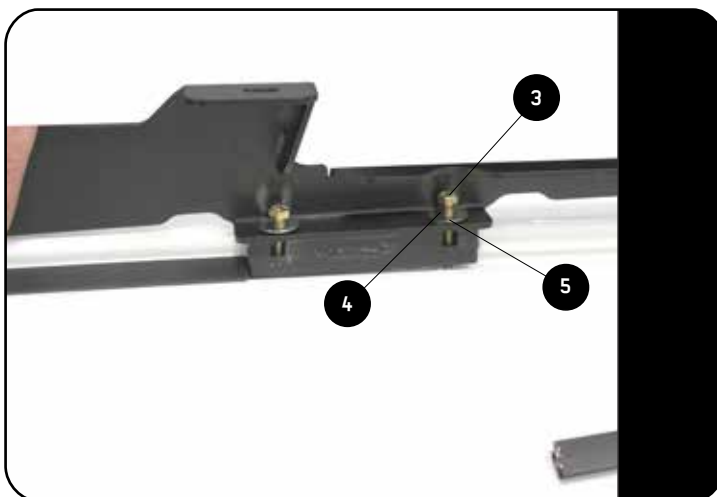

Drop the interior roof lining.

Using M6 x 50 Hex Bolts, M6 SS Spring Washers M6 x 19 x 1SS Flat Washers (Item 3, 4 & 5) and the Nut Plates (Item 7) to secure the Foot Rails to the vehicle. Refure to Step 2.6.

Finnish of by placing M6 Nut Caps (Item 2) on all the bolt heads.

Repeat this on both sides of the vehicle.

2.6

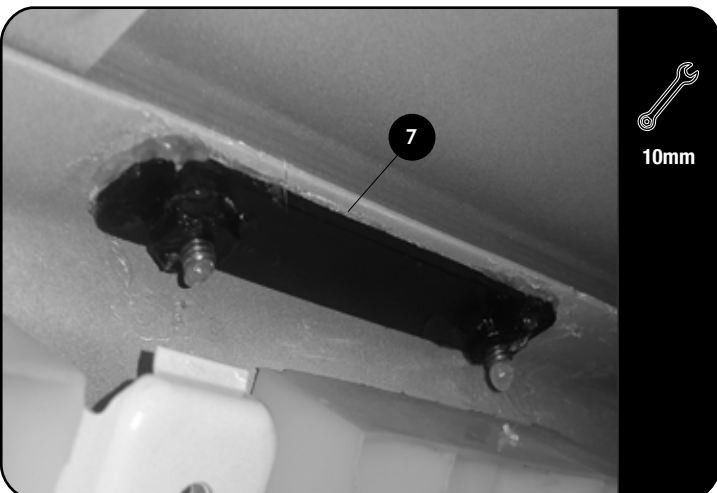

Place a bead of silicon on the four Nut Plates (Item 7). This is to bond the Nut Plates in place.

In future the Roof Rack together with the Foot Rail can be removed without dropping the roof lining.

Remove the Foot Rails and seal the holes by using the Foot Rail Sealing Kit (Item 12) (RRAC082).

3 FIT AND SECURE

3.1

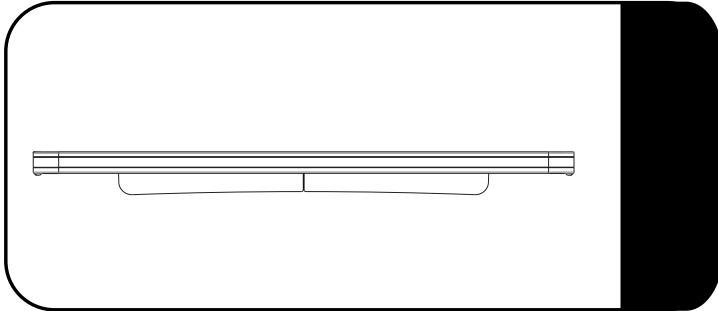

Make sure that the wind deflector is installed before you proceed to the next step.

3.2

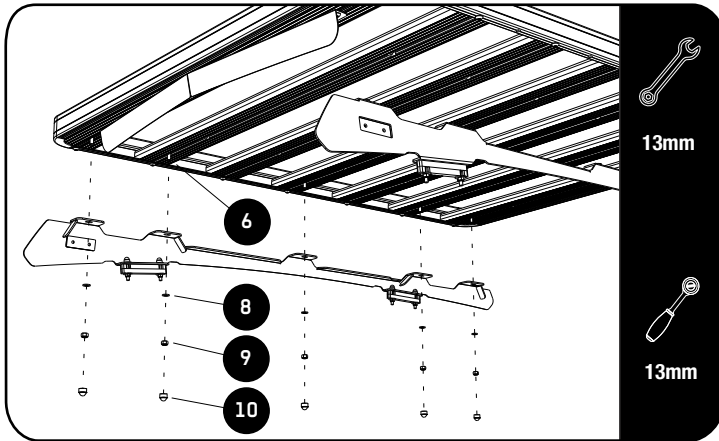

Fit your Roof Rack to the Foot Rails using M8 x 20 Hex Bolts, M8 x 16 x 1.6SS Flat Washers and M8 Nyloc Nuts (Items 6, 8 & 9).

3.3

Center the rack and tighten fully. Use M8 nut caps (Item 10) to finish off the nuts.



4

COMPLETION

4.1



Congratulations! You did it. Take a step back and admire your work!

5

INSTALL OTHER VEHICLE AND RACK ACCESSORIES

Now's the time to visit your favorite Front Runner Dealer in person or online.

Be sure to tag us. We love to see our gear in action! #FrontRunnerOutfitters #BornToRoam

Share your adventures on:  