

START HERE!

READ ME FIRST

Don't be a hero and muscle through this installation without reading these fitting instructions first! Improper installation of this gear may void certain aspects of your warranty.

Before you begin, take a moment and open all your Front Runner rack kit boxes and gather the assembly instructions for the various components.

A complete kit will contain:

1. A Front Runner Mounting System specific to your vehicle
2. A Front Runner Rack Tray or Load Bar Slats

This document will guide you through the assembly of the mounting system and assist you in fitting the roof rack tray or load bars to your specific vehicle.

Please refer to the next page for a list of all the components, quantities and tools required.

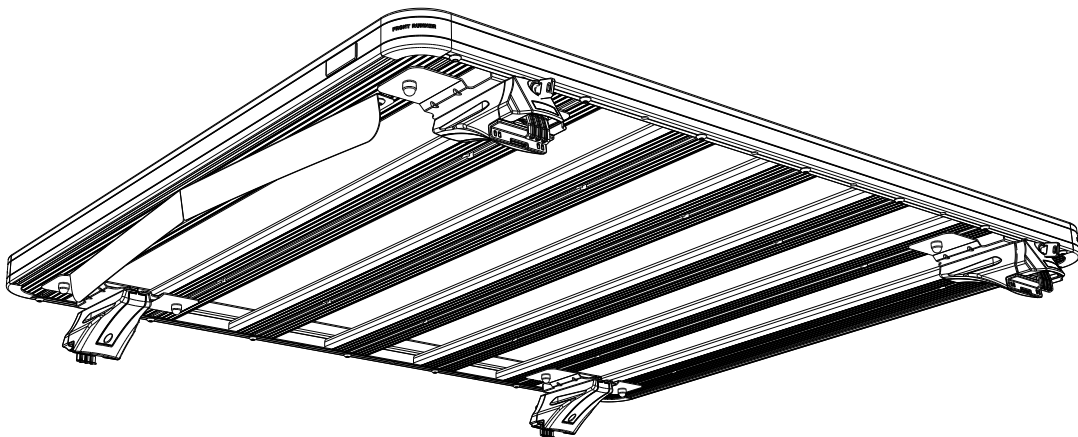

IMPORTANT WARNING! ⚠️

IT IS CRITICAL THAT ALL FRONT RUNNER PRODUCTS BE PROPERLY AND SECURELY ASSEMBLED AND ATTACHED TO YOUR VEHICLE. IMPROPER ATTACHMENT COULD RESULT IN AN AUTOMOBILE ACCIDENT, AND COULD CAUSE SERIOUS BODILY INJURY OR DEATH. YOU ARE RESPONSIBLE FOR ASSEMBLING AND SECURING ALL FRONT RUNNER PRODUCTS TO YOUR VEHICLE, CHECKING THE ATTACHMENTS PRIOR TO USE, AND PERIODICALLY INSPECTING THE PRODUCTS FOR ADJUSTMENT, WEAR AND DAMAGE. THEREFORE, YOU MUST READ AND UNDERSTAND ALL OF THE INSTRUCTIONS AND PRECAUTIONS SUPPLIED WITH YOUR FRONT RUNNER PRODUCT PRIOR TO INSTALLATION OR USE. IF YOU DO NOT UNDERSTAND ALL OF THE INSTRUCTIONS AND CAUTIONS, OR IF YOU HAVE NO MECHANICAL EXPERIENCE AND ARE NOT THOROUGHLY FAMILIAR WITH THE INSTALLATION PROCEDURES, YOU SHOULD HAVE THE PRODUCT INSTALLED BY A PROFESSIONAL INSTALLER OR OTHER QUALIFIED PERSONNEL.

NOTE: Front Runner will not be responsible for any damage caused by the failure to install the product according to these instructions.

Please call us if you have any questions about the installation of this product.



1 GET ORGANIZED

IN THE BOX

1	1 X	Tray
2	2 X	Leopard Foot With Lock / Pair
3	2 X	Raised Rail Adapter Plate / Pair
4	8 X	M8 x 16 Hex Bolt
5	8 X	M8 Flat Washers
6	8 X	M8 Nyloc Nut
7	8 X	M8 Nut Cap
8	2 X	Leopard Foot Without Lock / Pair

TOOLS NEEDED



FIGURE 1.1

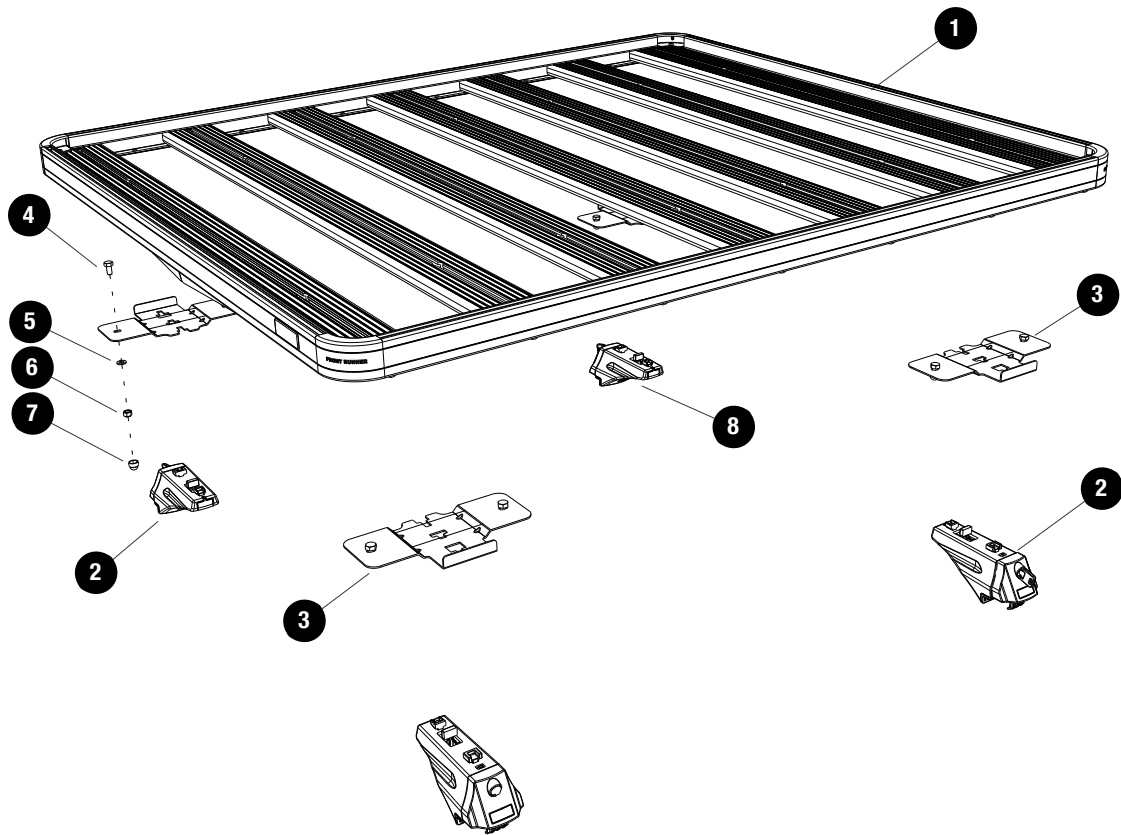

2

FIT AND SECURE

2.1

Refer to RRSUNI for assembly instructions of your Slimline II Tray.



2.2

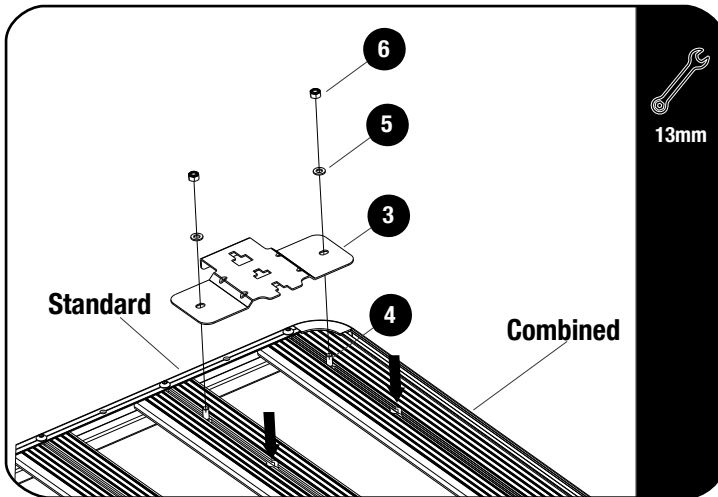

Flip the Rack so that the bottom of the Rack faces up. Insert two M8 x 16 Hex Bolts (Item 4) into the Combined slat and Standard slats machined slots as shown.

Loosely secure the Adapter Plate (Item 3) using M8 Nyloc Nuts and M8 Flat washers (Item 5 & 6).



The Feet will be fully tightened in 2.8.

2.3

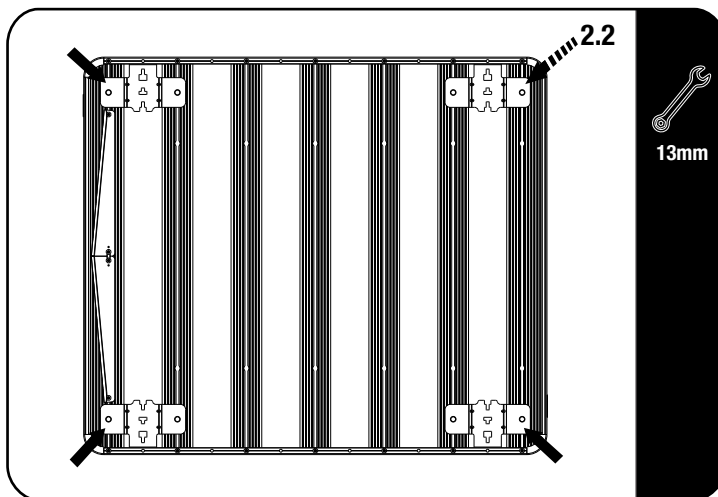

Repeat 2.2 on the remaining positions.

2.4

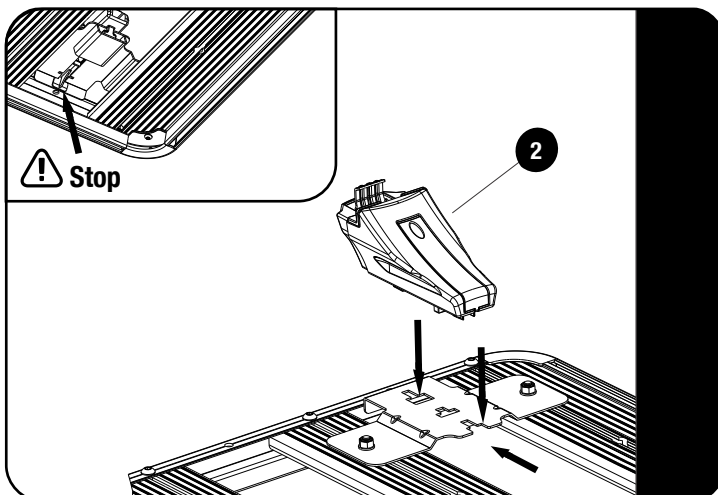

Slide the Foot (Item 2) into the Adapter Plate (Item 4) as shown.



Ensure that the Stop is pushed up against the inner tab on the Adapter Plate.

2

FIT AND SECURE

2.5

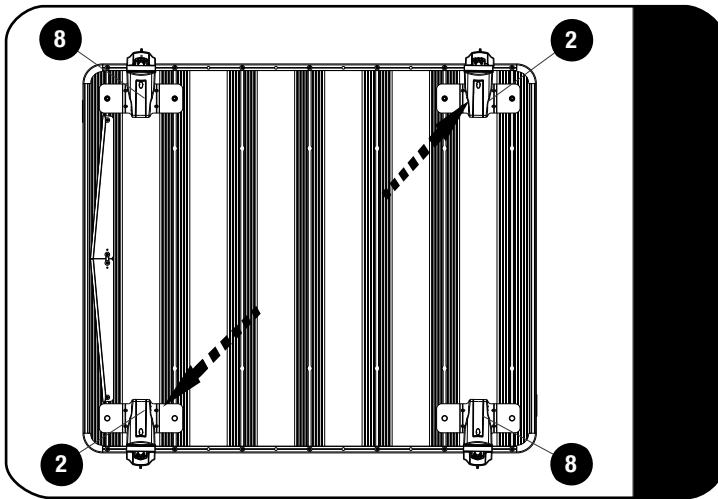

Repeat 2.4 on the remaining positions.

TIP: For better security, place the two Feet With Locks (Item 2) on the opposite side of each other.

2.6

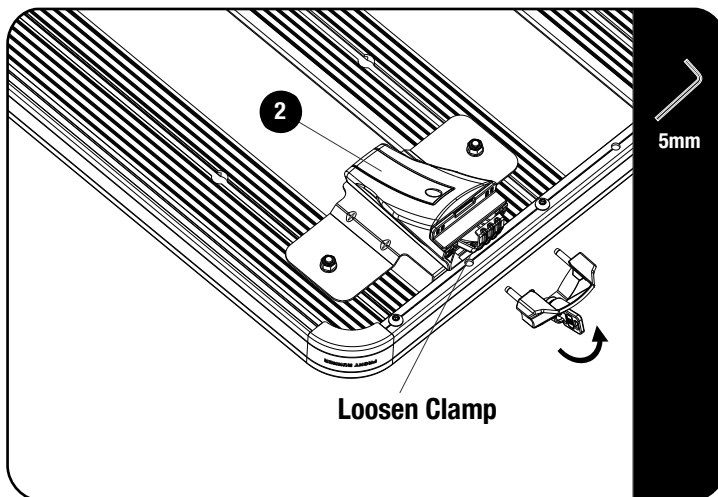

Unlock the covers on all four Feet and loosen the clamps using a 5mm Allen Key.

The clamps need to be loose enough so that the Feet will fit over your vehicles rails.

2.7

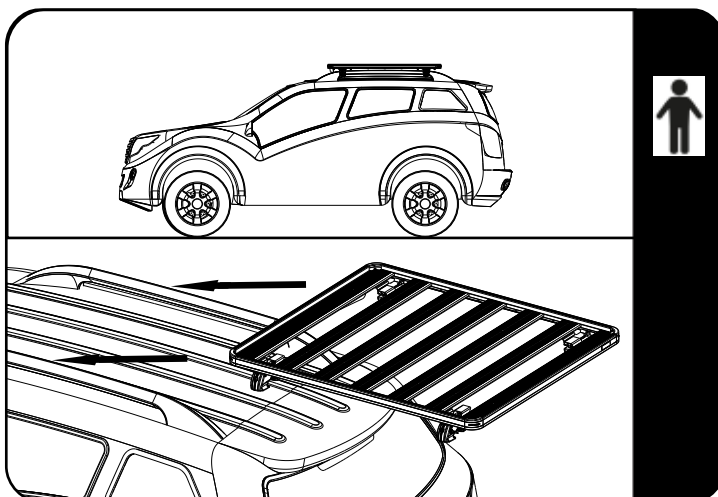

With the help of a friend, flip the rack over, right side up and place it onto the rails of the vehicle.

Find a suitable position so that the rack sits level.



VEHICLES FITTED WITH A SUNROOF:

Check that there is no interference between the Rack and Feet and the sunroof.

2

FIT AND SECURE

2.8

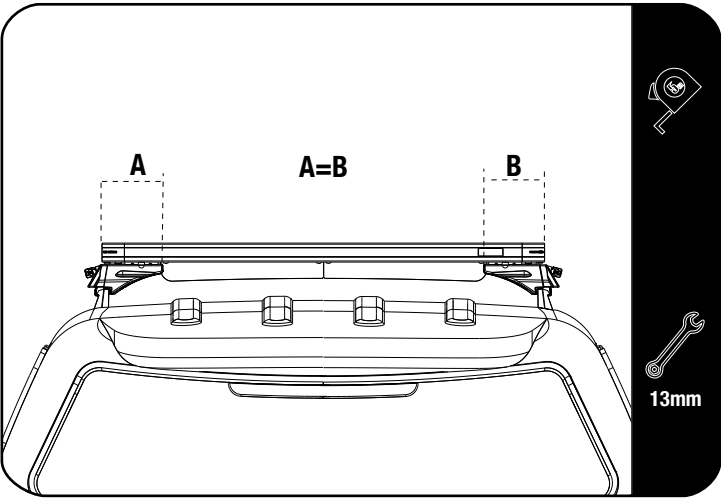

Center the Rack from left to right.

Using a 13mm spanner, fully tighten the M8 Nyloc Nuts from 2.2.

Ensure that the Stop is still pushed up against the inner tab on the Adapter Plate.

Tightening Torque:
M8 : 15-20Nm / 11.06 ft lb - 14.75 ft lb

2.9

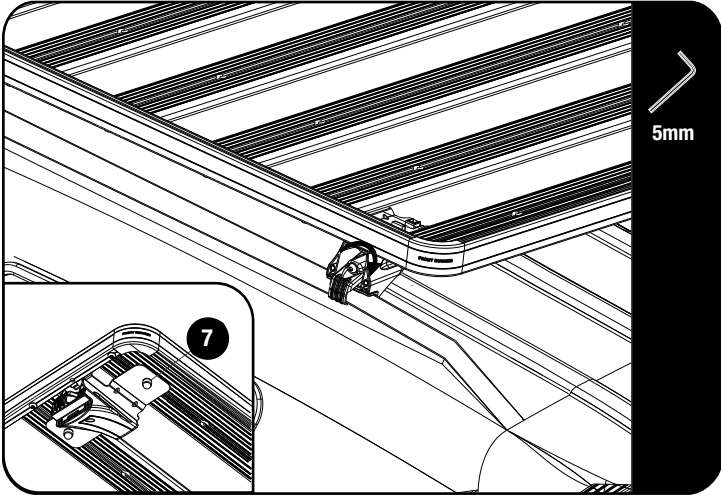

Fully tighten all four clamps.

Place M8 Nut Caps (Item 7) on all Nyloc Nuts.

Tightening Torque 8Nm / 6ft lb

2.10

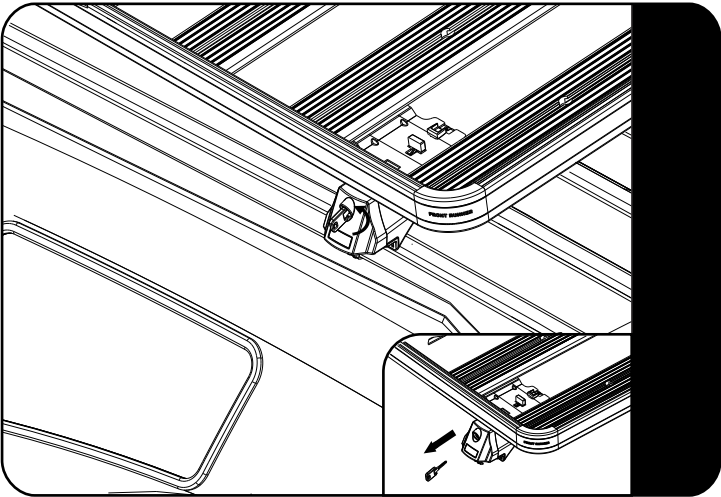

After all the feet are tightened refit the all four Foot covers.
Remove the key and store in a safe place.

3

3.1

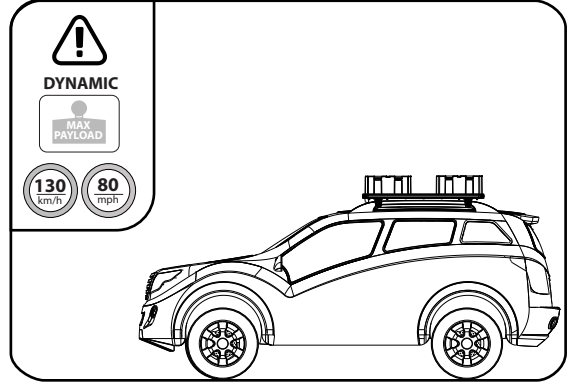
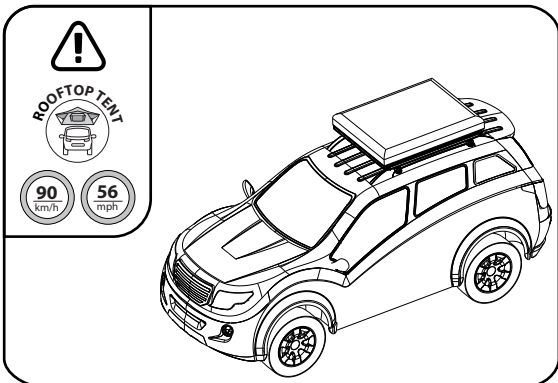
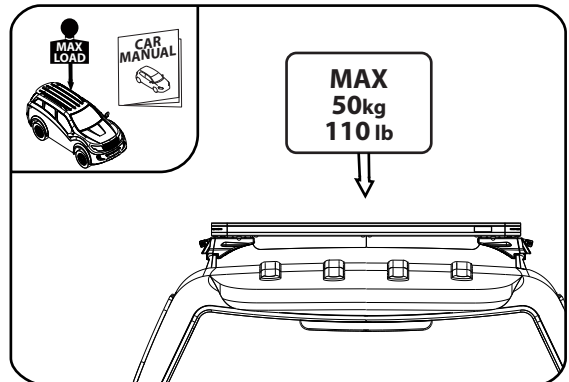
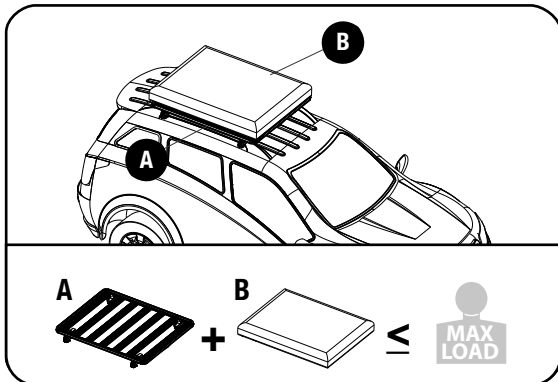

4

COMPLETION

4.1

Congratulations! You did it. Take a step back and admire your work!



5

INSTALL OTHER VEHICLE AND RACK ACCESSORIES

Now's the time to visit your favorite Front Runner dealer in person or online.

IMPORTANT! ⚠️

FRONT RUNNER RACK KITS OFTEN HAVE A HIGHER LOAD RATING THAN THE VEHICLES THEY ARE MOUNTED TO. PLEASE REFER TO YOUR SPECIFIC VEHICLE MANUFACTURER FOR A RECOMMENDED ROOF RATING. FRONT RUNNER CANNOT BE RESPONSIBLE FOR IMPROPER LOADING BEYOND THE VEHICLE MANUFACTURER'S STATED LOAD CAPACITY.

Be sure to tag us. We love to see our gear in action! #FrontRunnerOutfitters #BornToRoam

Share your adventures on: 