

READ ME !

Thank you for purchasing a Ineos Grenadier (2022-Current) Ladder.

Before you start, take a moment to familiarize yourself with the Fitting Instructions and the included components.

Refer to Page 2 for a list of all the components, quantities and tools required.

IMPORTANT WARNING!

IT IS CRITICAL THAT ALL FRONT RUNNER PRODUCTS BE PROPERLY AND SECURELY ASSEMBLED AND ATTACHED TO YOUR VEHICLE. IMPROPER ATTACHMENT COULD RESULT IN AN AUTOMOBILE ACCIDENT, AND COULD CAUSE SERIOUS BODILY INJURY OR DEATH. YOU ARE RESPONSIBLE FOR ASSEMBLING AND SECURING ALL FRONT RUNNER PRODUCTS TO YOUR VEHICLE, CHECKING THE ATTACHMENTS PRIOR TO USE, AND PERIODICALLY INSPECTING THE PRODUCTS FOR ADJUSTMENT, WEAR AND DAMAGE. THEREFORE, YOU MUST READ AND UNDERSTAND ALL OF THE INSTRUCTIONS AND PRECAUTIONS SUPPLIED WITH YOUR FRONT RUNNER PRODUCT PRIOR TO INSTALLATION OR USE. IF YOU DO NOT UNDERSTAND ALL OF THE INSTRUCTIONS AND CAUTIONS, OR IF YOU HAVE NO MECHANICAL EXPERIENCE AND ARE NOT THOROUGHLY FAMILIAR WITH THE INSTALLATION PROCEDURES, YOU SHOULD HAVE THE PRODUCT INSTALLED BY A PROFESSIONAL INSTALLER OR OTHER QUALIFIED PERSONNEL.

NOTE: Front Runner will not be responsible for any damage caused by the failure to install the product according to these instructions.

Please call us if you have any questions about the installation of this product.

1

GET ORGANIZED

IN THE BOX

1	2 X	Ladder sides (1005mm Long)
2	1 X	Ladder Top Bracket
3	2 X	Center Mounting Bracket
4	1 X	Bottom Mounting Bracket LH (154.39mm Long)
5	10 X	M6 Nut Cap
6	1 X	Bottom Mounting Bracket RH (170.38mm Long)
7	4 X	Ladder Steps (239mm Long)
8	8 X	M6 x 25 Thread Forming Screw
9	2 X	Rubber Step (202mm Long)
10	10 X	M6 x 16 Flange Button Head Screw
11	10 X	M6 Nyloc Nut
12	6 X	Crush Bush Assembly
13	6 X	M8 x 19 x 3 Flat Washer
14	6 X	M8 x 60 Hex Bolt
15	6 X	M8 Nut Cap

TOOLS NEEDED



FIGURE 1.1

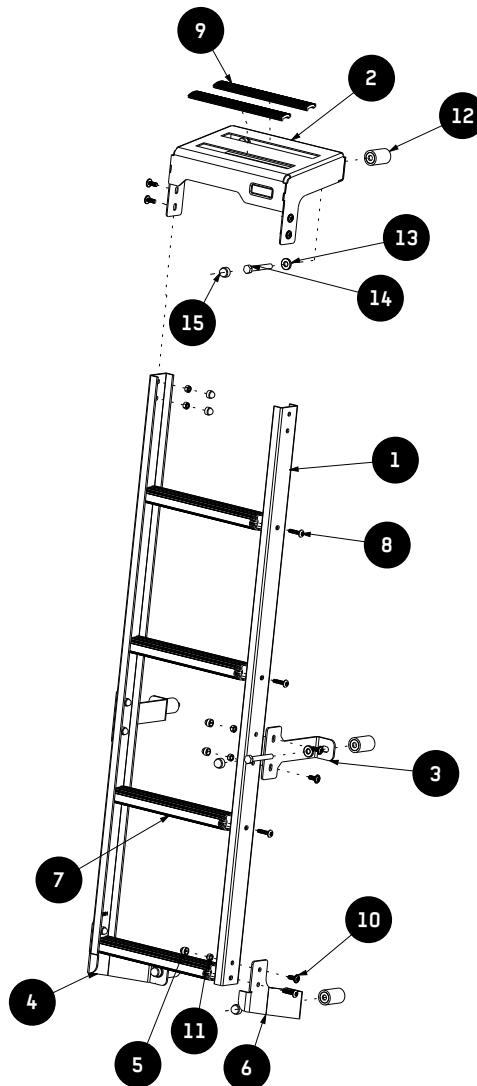

2

FIT AND SECURE

2.1



Torx T40



If the Vehicle has an OEM ladder fitted- Remove the 6 rubber gromets as indicated, from the ladder.

Using a T40 Torx remove the 6 bolts holding the ladder in place.

Once all 6 bolts are removed slide the ladder away from the rear door.

Keep the ladder and bolts in a safe place.

2.2

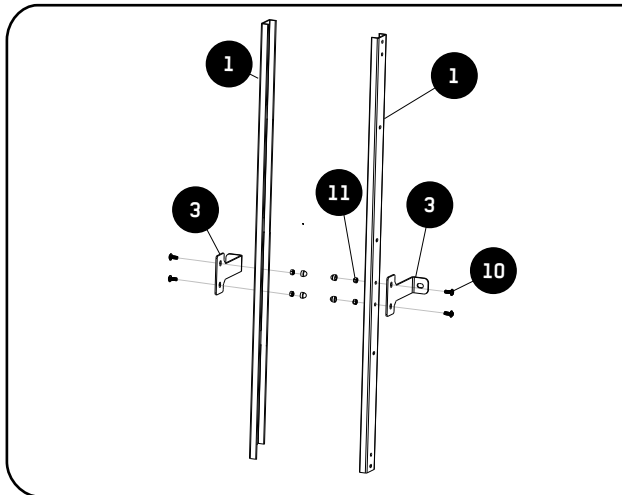

Torx T30



Loosely assemble the two Center Mounting Brackets (Item 3) to the Ladder Side profiles (Item 1) Using M6 x 16 Flange Button Head Screws and M6 Nyloc Nuts (item 10 & 11). DO NOT FULLY TIGHTEN.

2.3

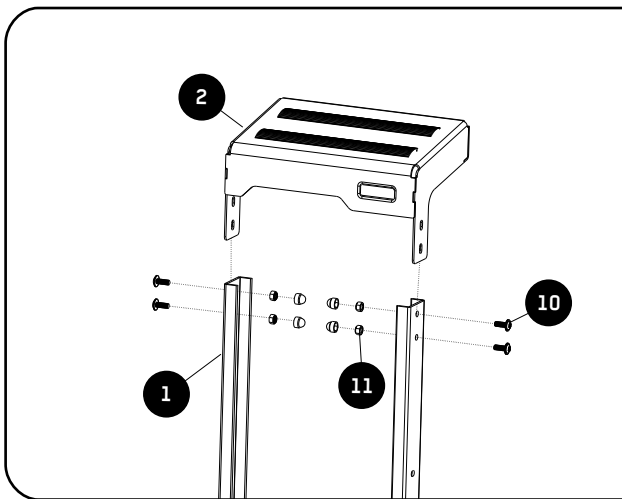

Torx T30



Loosely assemble the Ladder Top Bracket (Item 2) to the Ladder Side profiles (Item 1) Using M6 x 16 Flange Button Head Screws and M6 Nyloc Nuts (item 10 & 11). DO NOT FULLY TIGHTEN.

2

FIT AND SECURE

2.4

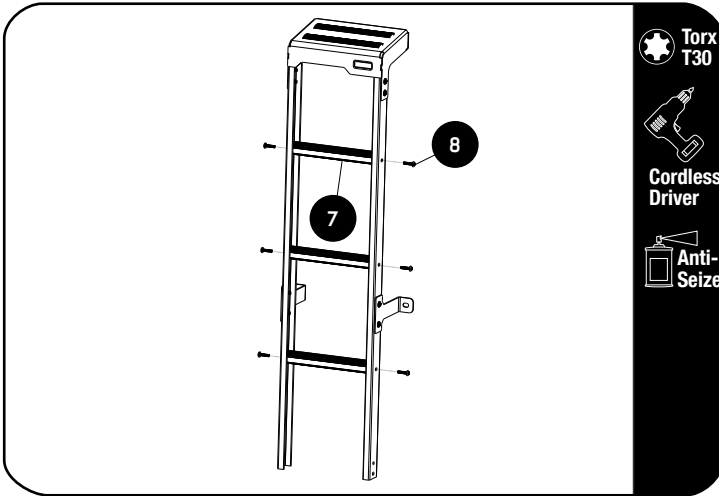

Assemble the three ladder Rungs (Item 7) to the Ladder side Profile using six M6 x 25 Thread forming screws (Item 8).



Apply anti seize on screw threads before inserting. Note these are thread forming screws.

2.5

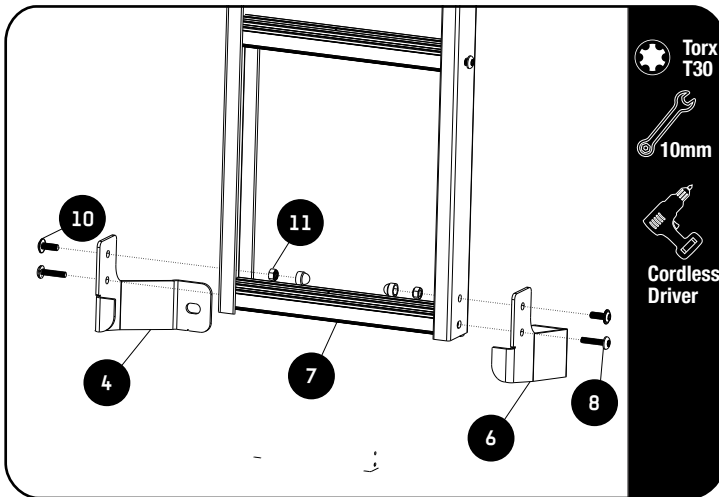

Assemble the bottom ladder Rung (Item 7) together with the two bottom mounting brackets (Item 4 & 6) to the Ladder side Profile using M6 x 25 Thread forming screws (Item 8) and M6 x 16 Button Head screws and M6 Nyloc Nuts (Item 10 & 11) as shown.



Take Note of the Bottom Mounting Brackets Item 6 is the RH side (170.50mm Long) and Item 4 is the LH side (154.50mm Long).



Apply anti seize on screw threads before inserting. Note these are thread forming screws.

2.6

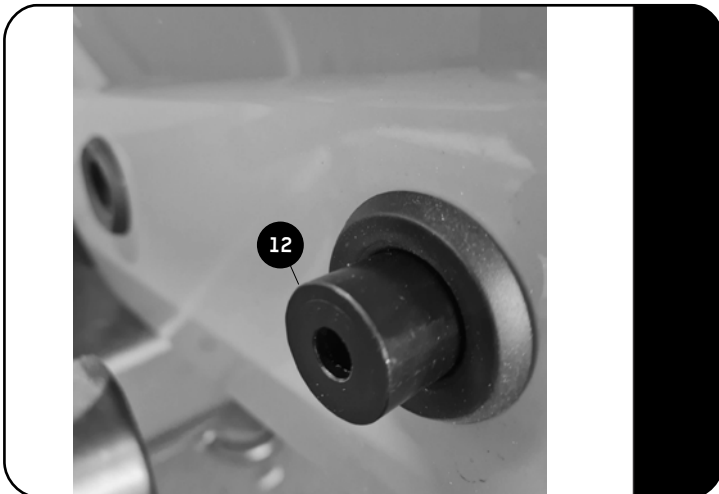

Slide the six Crush Bush assemblies (Item 12) into the six cavities in the rear door as shown.

2

FIT AND SECURE

2.7

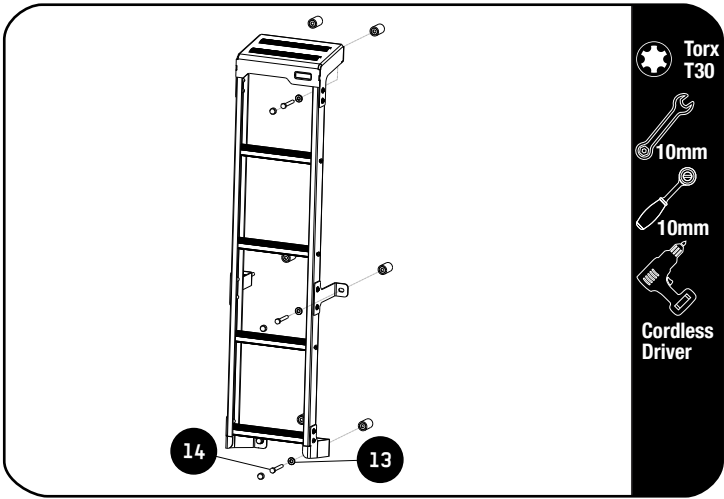

Fit the assembled Ladder to the Crush Bush Assembly fitted in 2.6 using M8 x 60 Hex Bolts and M8 x 19 x 3 Flat Washers (Item 8 & 14). Fully Tighten the M8 x 60 Hex Bolts. Fully Tighten all the M6 x 16 Button Head Screws that was loosely assembled.



Tightening Torque:

M6 : 8-10Nm / 5.9 ft lb - 7.38 ft lb



Tightening Torque:

M8 : 15-20Nm / 11.06 ft lb - 14.75 ft lb

2.8

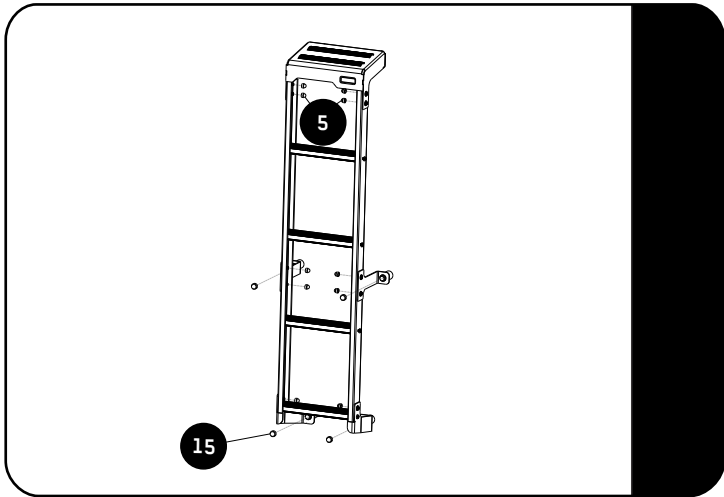

Place the M6 Nut caps (Item 5) over all the M6 Nyloc Nuts as shown. Place the M8 Nut caps (Item 15) over all the M8 Hex bolts as shown.

3

FINISH

Congratulations! You did it. Take a step back and admire your work!

4

INSTALL OTHER VEHICLE AND RACK ACCESSORIES

Now's the time to visit your favorite Front Runner Dealer in person or online.

Be sure to tag us. We love to see our gear in action! #FrontRunnerOutfitters #BornToRoam

Share your adventures on: 