**READ ME !** 

Thank you for purchasing a Front Runner Toyota Tundra Crew Cab (2022-Current) Slimsport Rack 40" Light Bar Wind Fairing

Before you start, take a moment to familiarize yourself with the Fitting Instructions and the included components.

Refer to Page 2 for a list of all the components, quantities and tools required.

IMPORTANT WARNING! 

IT IS CRITICAL THAT ALL FRONT RUNNER PRODUCTS BE PROPERLY AND SECURELY ASSEMBLED AND ATTACHED TO YOUR VEHICLE. IMPROPER ATTACHMENT COULD RESULT IN AN AUTOMOBILE ACCIDENT, AND COULD CAUSE SERIOUS BODILY INJURY OR DEATH. YOU ARE RESPONSIBLE FOR ASSEMBLING AND SECURING ALL FRONT RUNNER PRODUCTS TO YOUR VEHICLE, CHECKING THE ATTACHMENTS PRIOR TO USE, AND PERIODICALLY INSPECTING THE PRODUCTS FOR ADJUSTMENT, WEAR AND DAMAGE. THEREFORE, YOU MUST READ AND UNDERSTAND ALL OF THE INSTRUCTIONS AND PRECAUTIONS SUPPLIED WITH YOUR FRONT RUNNER PRODUCT PRIOR TO INSTALLATION OR USE. IF YOU DO NOT UNDERSTAND ALL OF THE INSTRUCTIONS AND CAUTIONS, OR IF YOU HAVE NO MECHANICAL EXPERIENCE AND ARE NOT THOROUGHLY FAMILIAR WITH THE INSTALLATION PROCEDURES, YOU SHOULD HAVE THE PRODUCT INSTALLED BY A PROFESSIONAL INSTALLER OR OTHER QUALIFIED PERSONNEL.

NOTE: Front Runner will not be responsible for any damage caused by the failure to install the product according to these instructions.

Please call us if you have any questions about the installation of this product.



1 GET ORGANIZED

IN THE BOX

1	1 X	Wind Fairing
2	1 X	Wind Fairing Mounting Bracket LH
3	1 X	Wind Fairing Mounting Bracket RH
4	2 X	Center Support Bracket
5	1 X	Stiffener Bracket LH
6	1 X	Stiffener Bracket RH
7	1 X	Light Bar Bracket High Profile LH
8	2 X	Light Bar Bracket Low Profile
9	1 X	Light Bar Bracket High Profile RH
10	4 X	M8 x 16 Hex Screw
11	4 X	M8 Nyloc Nut
12	14 X	M6 x 16 Button Head Flange Bolt
13	1 X	Wind Fairing Rubber 1100mm Long

IN THE BOX

14	2 X	M8 x 12 Button Head Screw
15	2 X	M8 Thin Nut
16	2 X	M8 Nut Cap

TOOLS NEEDED

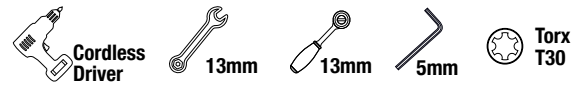
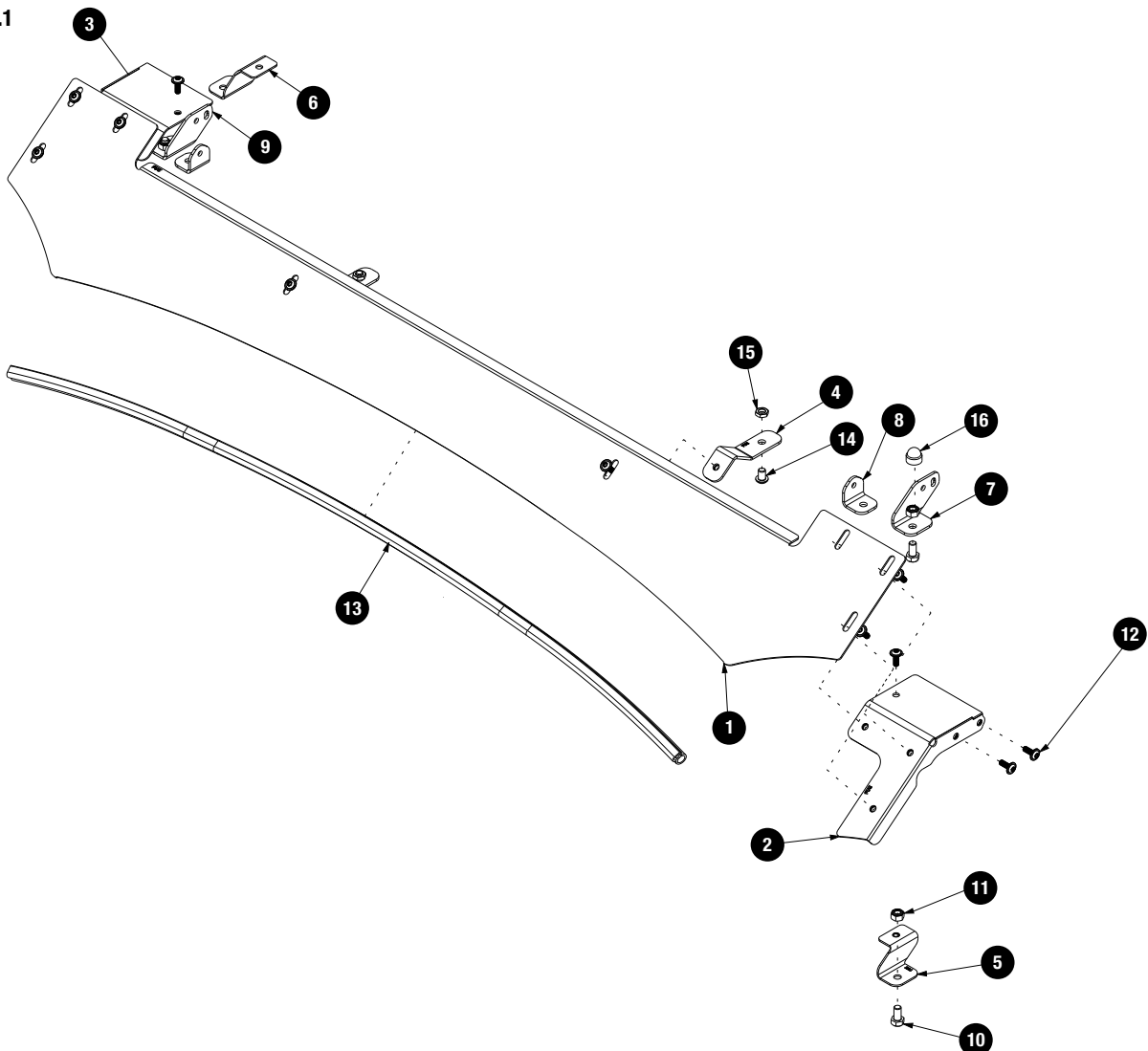

FIGURE 1.1



2

FIT AND SECURE

2.1

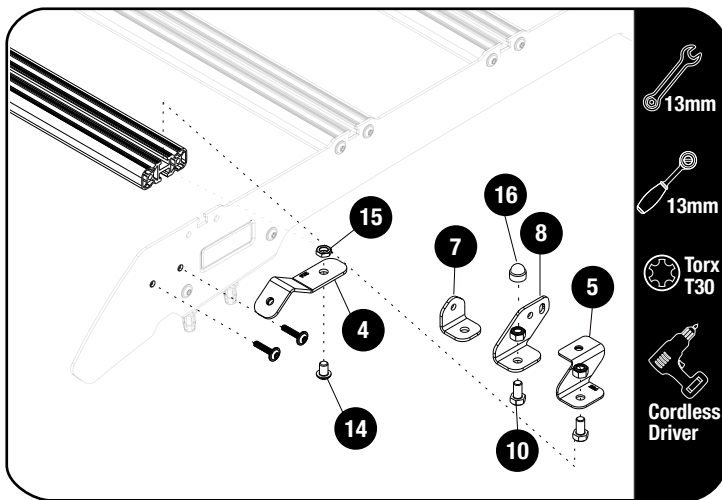

Start by removing the four M6x25 thread forming screws securing the front slat, two per side. Slide four M8x20 hex head bolts (Item 10) into the slat top T slot for the light bar brackets and support brackets (Item 5).

Choose which lightbar bracket is best suited for your lightbar and fit using M8x20 bolt inserted earlier and M8 nyloc nut. DO NOT FULLY TIGHTEN

Slide two M8 thin nuts (item 15) into the bottom T slot and fit center support brackets (item 4) using M8 button head screw (item 14) DO NOT FULLY TIGHTEN.

Refit the front slat to the lower mounting holes using the M6x25 thread forming screws

2.2

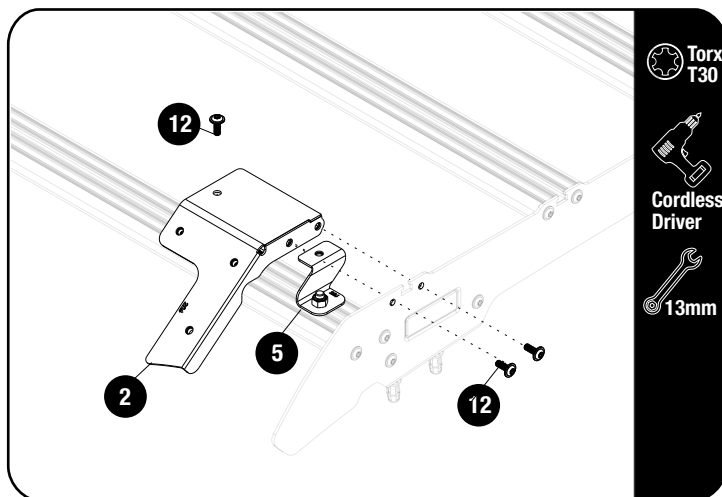

Fit the Side mount bracket (Item 2) to the two top holes in the foot rail as shown using the M6 x 16 button head flange screws (Item 12) and fully tighten.

Slide the stiffener bracket assembled in 2.1 and align with top hole in side mount bracket and tighten with the M6 x 16 Button head flange screw. Fully tighten all the M8 x 16 Bolts and the M8 Nyloc Nuts.

Place a M8 Nut Cap (Item 16) over each M8 Nyloc Nuts.



Tightening Torque:

M6 : 8-10Nm / 5.9 ft lb - 7.38 ft lb



Tightening Torque:

M8 : 15-20Nm / 11.06 ft lb - 14.75 ft lb

2.3

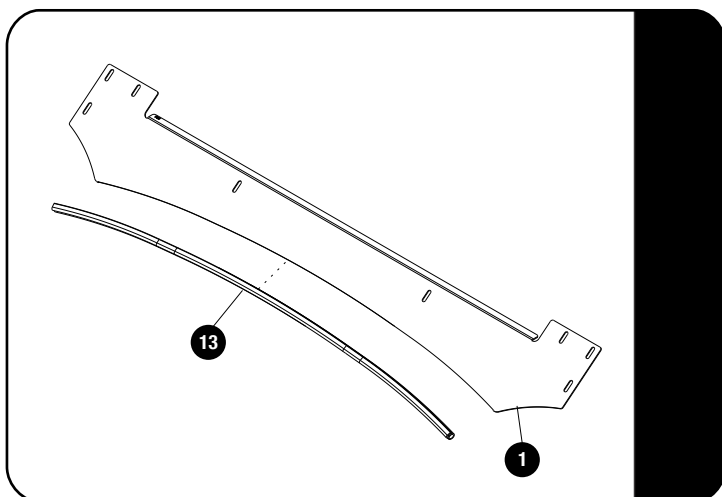

Before moving to the next step make sure that the Wind Fairing rubber (Item 13) is fitted to the Wind Fairing (Item 1).

2

FIT AND SECURE

2.4

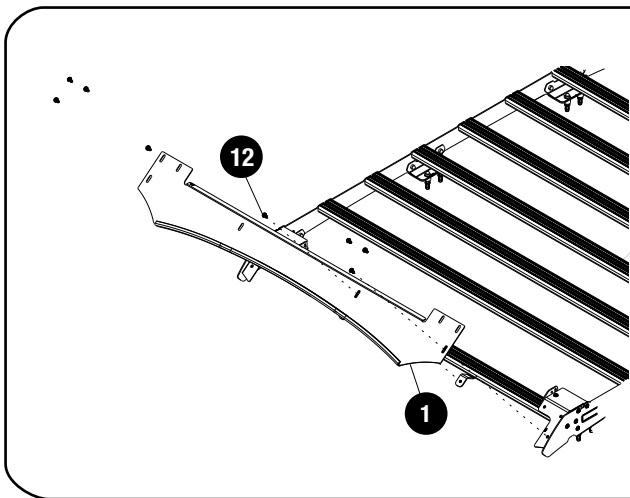

Torx
T30

Cordless
Driver



Position the wind fairing over the side brackets and insert one M6x16 flange head screw (Item 12) into each of the the side brackets. Align the center brackets with the middle slots in the wind fairing and insert one M6x16 (Item 12) flange head screw into each slot. Fully tighten the two M8x12 button head screws (Item 14) below holding the center brackets.

Insert the remaining four M6x16 flange head bolts into the wind fairing. Adjust fairing down to the roof, insuring the rubber on the trim sits evenly. **FULLY TIGHTEN ALL FASTENERS**



Tightening Torque:

M6 : 8-10Nm / 5.9 ft lb - 7.38 ft lb



Tightening Torque:

M8 : 15-20Nm / 11.06 ft lb - 14.75 ft lb

2.5

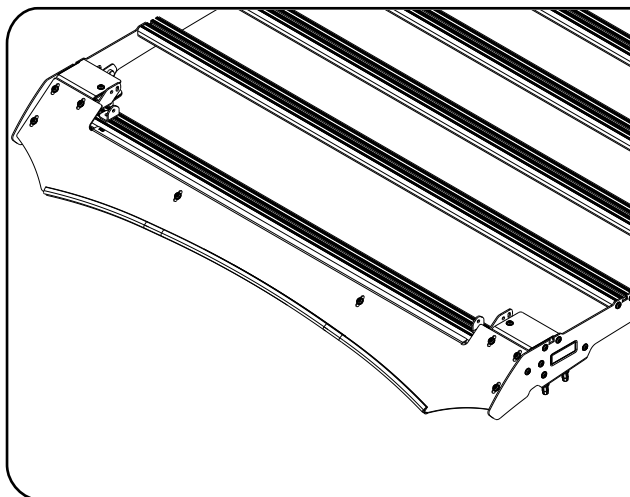

5mm



Adjust light bar brackets to suit light bar that has been fitted and fully tighten the screws.



Tightening Torque:

M8 : 15-20Nm / 11.06 ft lb - 14.75 ft lb

3

FINISH

Congratulations! You did it. Take a step back and admire your work!

4

INSTALL OTHER VEHICLE AND RACK ACCESSORIES

Now's the time to visit your favorite Front Runner Dealer in person or online.

Be sure to tag us. We love to see our gear in action! #FrontRunnerOutfitters #BornToRoam

Share your adventures on:

