



FRONT RUNNER
VEHICLE OUTFITTERS

LOAD BED CARGO SLIDE MKIII - LARGE

ENG

SSBS009

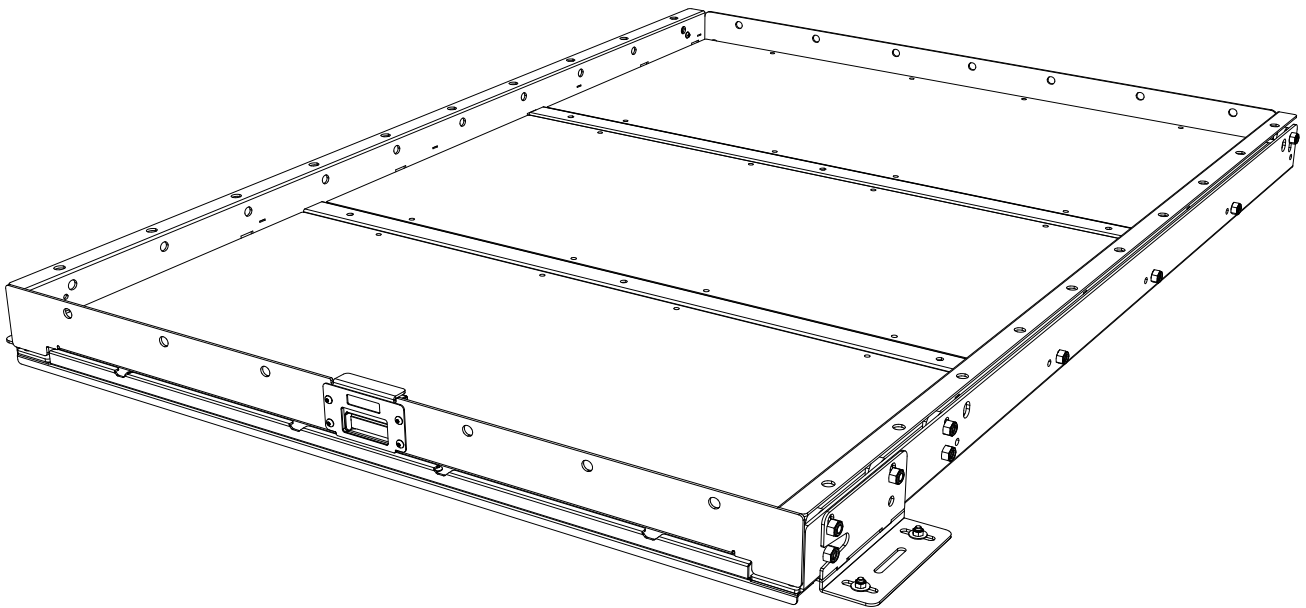

READ ME !

Thank you for purchasing a Front Runner Load Bed Cargo Slide.

Before you start, take a moment to familiarize yourself with the Fitting Instructions and the components received.

Refer to Page 2 for a list of all the components, quantities and tools required.

NOTE: Front Runner will not be responsible for any damage caused by the failure to install the product according to these instructions.
Please call us if you have any questions about the installation of this product.

IMPORTANT WARNING!

IT IS CRITICAL THAT ALL FRONT RUNNER PRODUCTS BE PROPERLY AND SECURELY ASSEMBLED AND ATTACHED TO YOUR VEHICLE.

IMPROPER ATTACHMENT COULD RESULT IN AN AUTOMOBILE ACCIDENT, AND COULD CAUSE SERIOUS BODILY INJURY OR DEATH.

YOU ARE RESPONSIBLE FOR ASSEMBLING AND SECURING ALL FRONT RUNNER PRODUCTS TO YOUR VEHICLE. CHECKING THE ATTACHMENTS PRIOR TO USE, AND PERIODICALLY INSPECTING THE PRODUCTS FOR ADJUSTMENT, WEAR AND DAMAGE. THEREFORE YOU MUST READ AND UNDERSTAND ALL OF THE INSTRUCTIONS AND PRECAUTIONS SUPPLIED WITH YOUR FRONT RUNNER PRODUCT PRIOR TO INSTALLATION OR USE.

IF YOU DO NOT UNDERSTAND ALL OF THE INSTRUCTIONS AND CAUTIONS, OR IF YOU HAVE NO MECHANICAL EXPERIENCE AND ARE NOT THOROUGHLY FAMILIAR WITH THE INSTALLATION PROCEDURES, YOU SHOULD HAVE THE PRODUCT INSTALLED BY A PROFESSIONAL INSTALLER OR OTHER QUALIFIED PERSONNEL.

1

GET ORGANIZED

Here is what you are looking at for SSBS009

IN THE BOX

1	1 X	Load Bed Cargo Slide MKIII - LARGE
2	1 X	M6x25 Countersink Bolt
3	1 X	M10 Flat Washer
4	9 X	M6x40 Hex Bolt
5	2 X	M8 Nyloc Nut
6	5 X	M6x25 Hex Bolt
7	10 X	M6 Rivnut
8	9 X	M6 Spring Washer
9	6 X	19x12.58x12 Aluminium Spacer
10	9 X	M6x30x1 Flat Washer
11	1 X	M6x35 Hex Bolt
12	1 X	M6x40 Hex Bolt
13	1 X	M6 Normal nut
14	1 X	M6x12x1 Flat Washer

TOOLS NEEDED

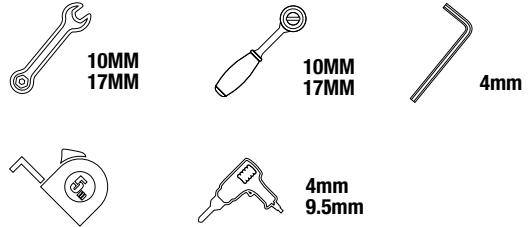
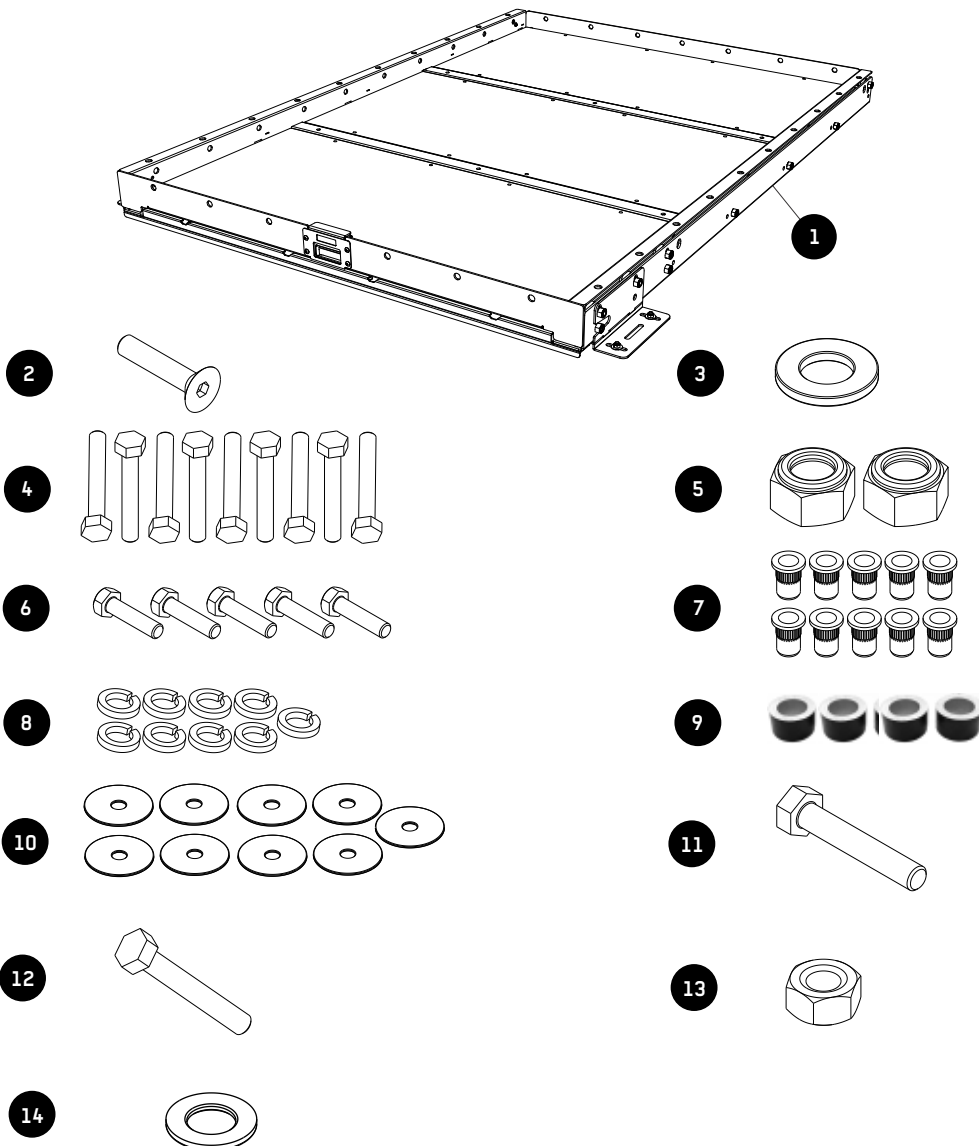

FIGURE 1.1



2

FIT AND SECURE

2.1

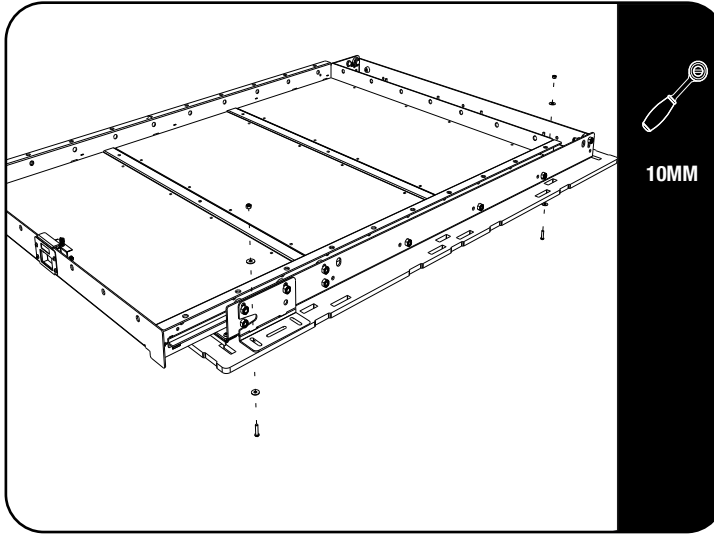

Before fitting the Cargo Slide in the vehicle, remove the wood base by loosening the four M6 Button Head Bolts.

To loosen the two rear bolts, open the Cargo Slide.

2.2

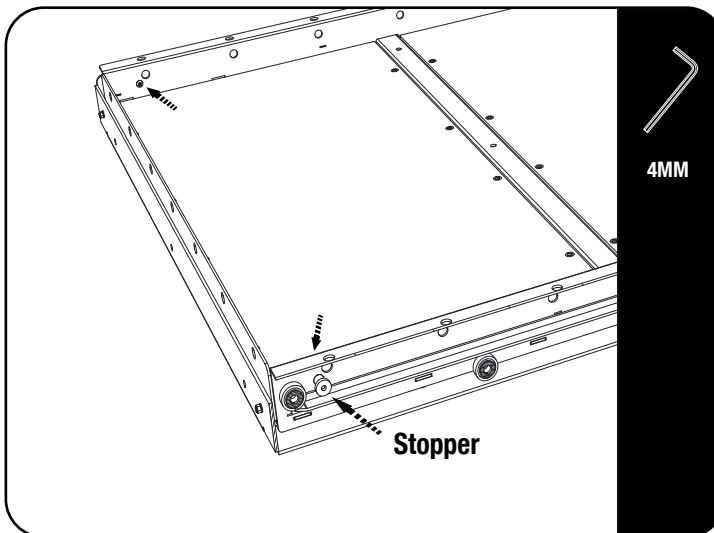

Looking at both the left and right rear corners of the Cargo Slide (Item 1), loosen and remove the rubber stopper. This is done by gripping the stopper to prevent it from turning and removing the M6 button head bolt as shown. Once removed keep in a safe place as you will need to replace them at a later stage.

Place the Cargo Slide into the vehicles load bed. Carefully pull the "tray" free from the frame and store in a safe place until later.

2.3

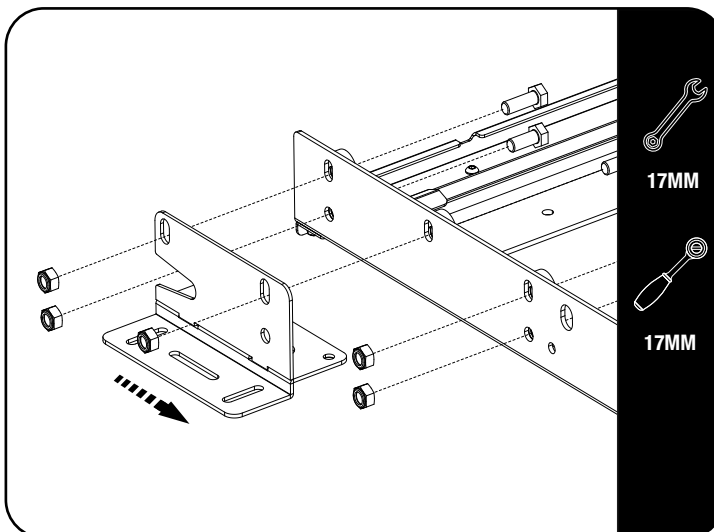

Position the frame, front to back and left to right. Load beds vary with each manufacturer, so the exact positioning of the frame will vary from vehicle to vehicle. It is advisable to get all mounting points in the center of the raised sections that run the length of the load bed, however in the event of mounting points not lining up with raised sections, spacers have been provided.

The front mounting brackets may be relocated backwards should it be required to obtain a more suitable mounting position as shown in diagram 2.3.

2

FIT AND SECURE

2.4

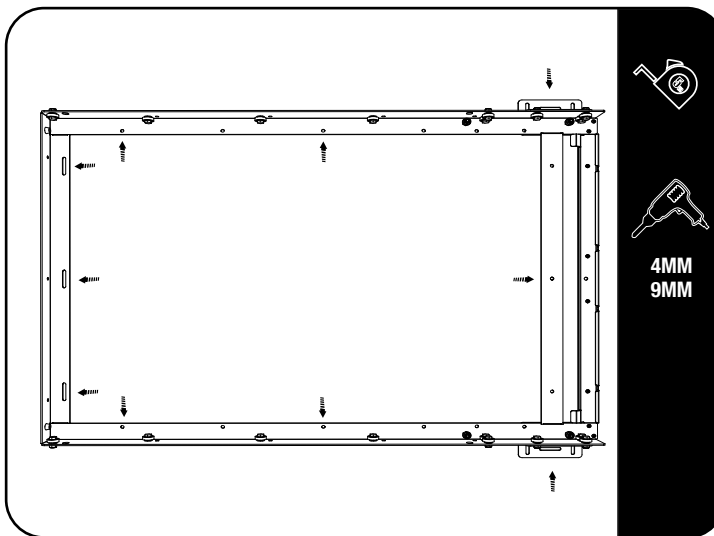

Make sure you have closed the load bed tail gate to ensure that it does not make contact with the frame. Once you are satisfied with the positioning of the frame, mark the position of all the mounting points as indicated by the arrows onto the load body.

Remove the frame and drill a 4mm pilot hole on each of your markings. Check the underside of the load bed before drilling to make sure that there is no piping or wiring in the way. Re-drill all of the pilot holes to 9mm.

Insert and crimp a M6 rivnut (Item 6) into each of the holes you have drilled.

2.5

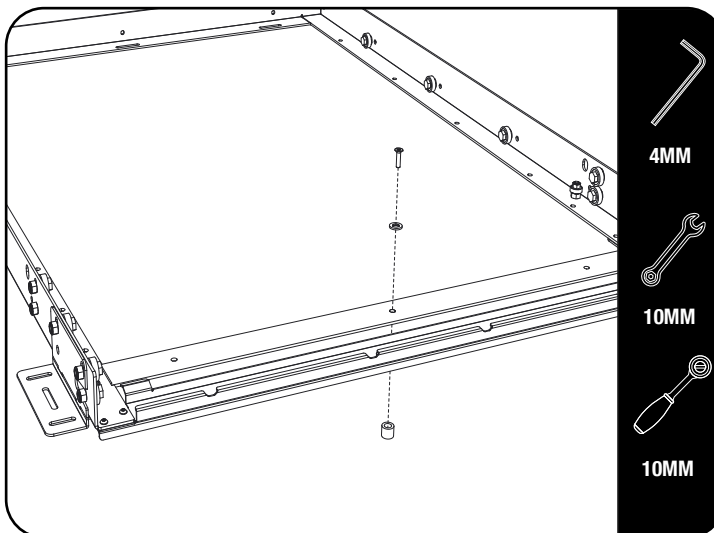

Place the frame back onto the load bed and secure using the fasteners and spacers supplied. The spacers (Item 5) are to be used when the mounting points are in a "dip" and not on a raised section by placing it over the rivnut so that the frame rests on the spacer.

When securing the front of the frame use the M6x25 countersunk screw, M10 flat washer and a spacer

2.6

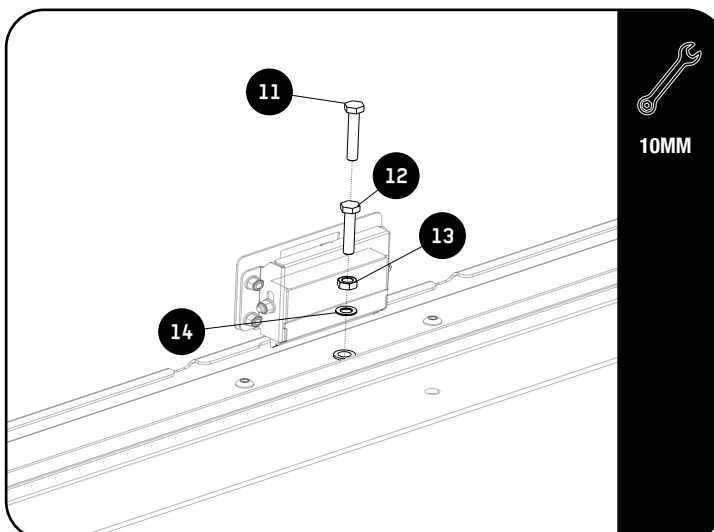

Before refitting the slide to the frame, use the M6 x 35 or M6 x 40 hex bolt (Item 11 or 12) (depending on which fits the specific vehicle best) together with the M6 Normal nut and M6 x 12 x 1 Flat washer (Item 13 & 14) and assemble as shown.

Turn the Bolt until the bottom of the bolt touches the load bin then tighten the M6 normal nut to lock the M6 bolt in place.

! The above adjustment can be repeated as needed.

! **Tightening Torque:**
M6 : 8-10Nm / 5.9 ft lb - 7.38 ft lb

2

FIT AND SECURE

2.7

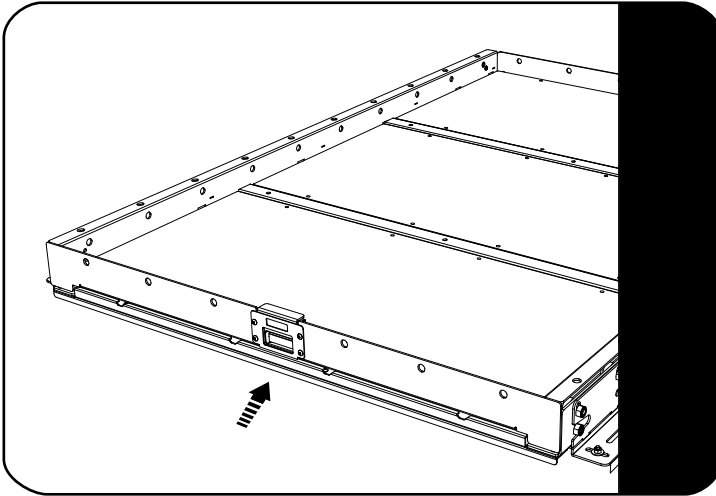

Refer to Step 2.2, refit the tray and stoppers. Once refitted check that the push to close latch engages fully and that the slide is secure.

If the Lock does not Lock properly adjust the bolt inserted in 2.6.

3

COMPLETION

3.1

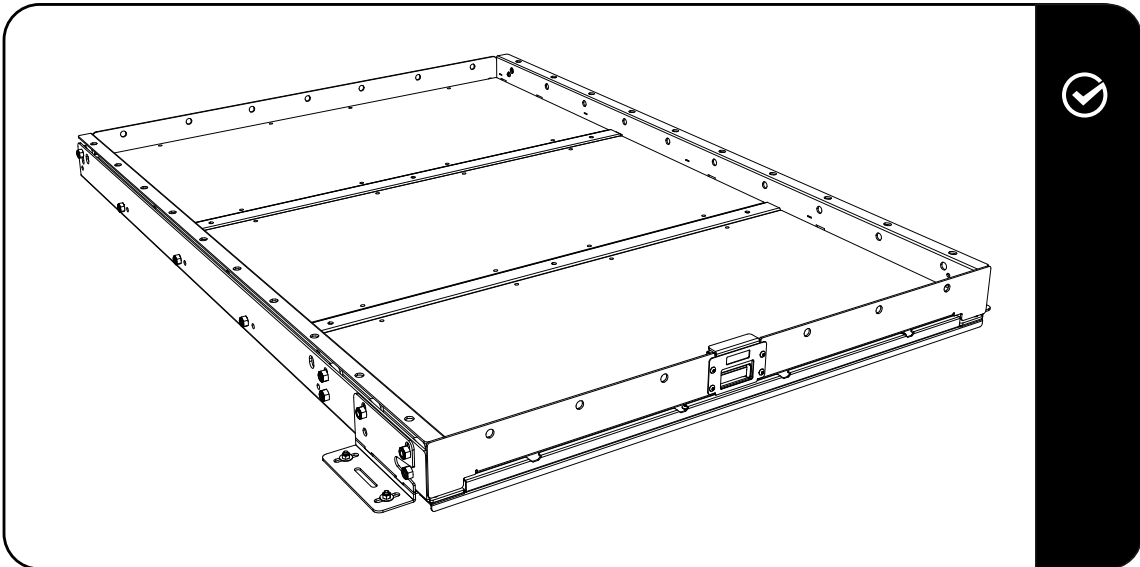

Congratulations! You did it. Take a step back and admire your work!

4

INSTALL OTHER VEHICLE AND RACK ACCESSORIES

Now's the time to visit your favorite Front Runner Dealer in person or online.